

User manual

REPEATORK

Original manual V2.0

Table of Contents

I.	General description.....	4
II.	Technical Specifications	5
III.	Available options.....	5
IV.	User manual	6
A.	Installing the device	6
B.	Mounting and centering the torque meter.....	6
C.	Mounting the supports on the torque meter	6
D.	Mounting the clamp or mold jaw.....	9
E.	Disassembly of the device.....	10
F.	Using the device	10
a.	General	10
b.	Interfaces and movement settings.....	11
1.	Main screen.....	11
2.	Movement settings	11
3.	Select the direction of the movement to be performed and start the movement	15
a.	Manual rotation lock.....	16
b.	Screen lock	16
c.	Torque meter configuration.....	16
G.	Using the digital ruler (OPTION).....	17
a.	Operation	17
b.	Setting the zero	18
H.	Using the child safety cap activation system or CRC (OPTIONAL)	19
a.	Installation diagram.....	20
b.	Description and operation	21
V.	Maintenance - Maintenance operations.....	24
A.	Maintenance	24
B.	Cleaning.....	24
VI.	Transportation outside the device's operating site	25
VII.	FAQ – Frequently asked questions.....	25
VIII.	Declaration of conformity	26
IX.	APPENDICES	27

NOTE

THE FUNCTIONING OF THE BUTTONS IS DETAILED IN SECTION No. V / E / 3: *"Select the direction of movement to be performed and start the movement."*

Safety instructions

Throughout this document, the pictogram  informs you of important safety information.

The pictogram  alerts you to additional information that aids understanding.



GENERAL SAFETY INSTRUCTIONS

- Read the instructions before use
- One user per machine
- Wear safety glasses to avoid contact with any product splashes.
- Wear gloves when using hazardous products (acids, soda, toxic products)
- Wear gloves and safety shoes when moving the machine.
- Do not place your hands under the device and do not handle samples when using the up/down wheel



RESIDUAL SAFETY INSTRUCTIONS

- Do not approach accessible parts during rotation.
- Do not place your hands under the device or handle samples when using the up/down wheel.
- If two-hand operation is disabled, be sure not to place your hands or any other part of your body near the rotating machine.
- Also, do not wear loose clothing or long accessories (such as scarves) that could become entangled in the rotating shaft of the machine.
- Handle the device with care. Refer to the manual to identify the PPE (personal protective equipment) to be used for each application.
- Use the device exclusively on a stable, flat surface.
- In the presence of hazardous liquids (corrosive, toxic, or irritating) or warm liquids (above 40°C), wear appropriate protective gloves and goggles.
- It is strictly forbidden to use the device for liquids with a temperature above 60°C.
- The device is not designed for use with cryogenic or pressurized products.
- This equipment is not designed or certified for use in explosive atmospheres (ATEX). Its use in such areas is strictly prohibited.
- Check the torque to be applied before any handling to prevent the risk of glass breakage. Wear suitable gloves for all tightening operations.
- Be aware of the risk of pinching associated with the spring-loaded mechanism.

I. General description

The REPEATORK is designed to motorize the tightening and loosening of samples, offering the possibility of:

- Reuse existing torque meters
- Avoid musculoskeletal disorders (MSDs).
- Improve repeatability

The REPEATORK consists of a base plate to which a torque meter must be attached (most models are compatible), a power supply unit, and a motor unit that slides onto the mast to adjust to the height of the samples.

The REPEATORK is supplied without a torque meter, and the clamping jaw is supplied according to your needs and the advice of your dealer.

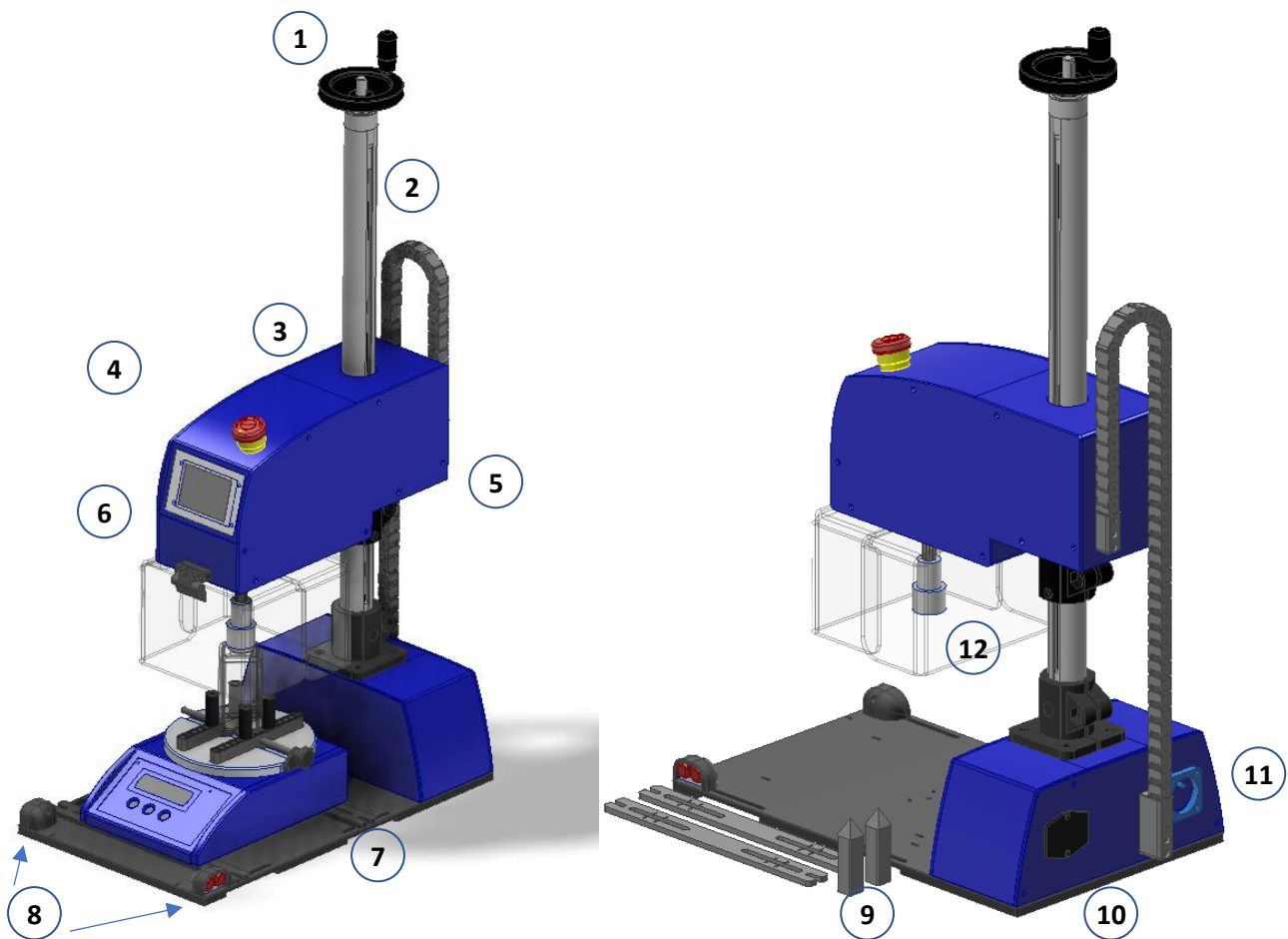

1: Engine block "up/down" flywheel

2: "Up/down" mast

3: Motor block

4: Control panel (touch screen)

5: Cable carrier track

6: Safety visor

7: Torque meter adapter bracket (for mounting and centering)

8: 4 buttons: 2 for two-hand control, 2 for selecting rotation and cycle start.

9: Centering cones

10: Power supply socket

11: Remote power supply socket for torque meter (auxiliary power supply)

12: Rotation axis on which the clamp must be attached

II. Technical specifications

	REPEATORK
Dimensions (mm)	L300xD500xH700
Weight	20 kg
Power supply	110V / 230V – 50Hz / 60Hz
Maximum sample height	250 mm (530 mm optional)
Maximum sample diameter	140mm
Environment	4°C to 37°C Relative humidity: 30% to 80% RH
Display	3.5" touchscreen
Minimum rotation speed	1 revolution/minute
Maximum rotation speed	60 revolutions/minute
Maximum torque	10 N.m
IP rating	IP 54
Noise level	<40 dB
Power consumption	0.5 kW

III. Available options

- Shaped jaws
- HELITORK clamping
- Connection to an ACRN torque meter
- Digital height gauge
- Safety cap support device during rotation (CRC)

IV. User manual

A. Installation of the device



PLEASE READ THE SAFETY INSTRUCTIONS BEFORE INSTALLATION

INSTALLING THE REPEATER, ASSEMBLING AND CENTERING THE COUPLING METER

- Unpack the device from its box. Keep the original box for reuse in case of future transport.
- Handle the equipment with care, using two people. Wear gloves and shoes when moving it.
- Install the device on a flat, horizontal surface that is sturdy enough to support its weight.
- Do not install the device in a hot and humid environment, for example next to a heat source such as a radiator.
- To limit the risk of contact with rotating parts, it is important not to install the device in a high-traffic area of the workshop.
- Ensure uniform lighting of at least **500 lux** on the work surface in order to read the displayed values correctly and handle the samples safely.

B. Mounting and centering the torque meter



CENTERING THE TORQUE METER AND THE ROTATION AXIS IS ESSENTIAL DURING INSTALLATION.

APPROXIMATE CENTERING WILL NOT PROVIDE RELIABLE TORQUE MEASUREMENTS.

ALL THE STEPS DESCRIBED BELOW MUST BE PERFORMED CAREFULLY TO AVOID DAMAGING THE SENSOR

C. Mounting the brackets on the torque meter

1. Remove the feet from the torque meter
2. Screw the support plates as described below without tightening them too much
3. Positioning lines allow you to pre-center the torque meter approximately on these brackets
4. Tighten the screws
5. Install the torque meter and brackets on the base plate
6. Install the centering cones on the rotation axis and in the torque meter clamp, and lower the motor block
7. Adjust the position of the torque meter and tighten the screws to lock the position by tightening the 4 screws firmly

Screws in place of feet

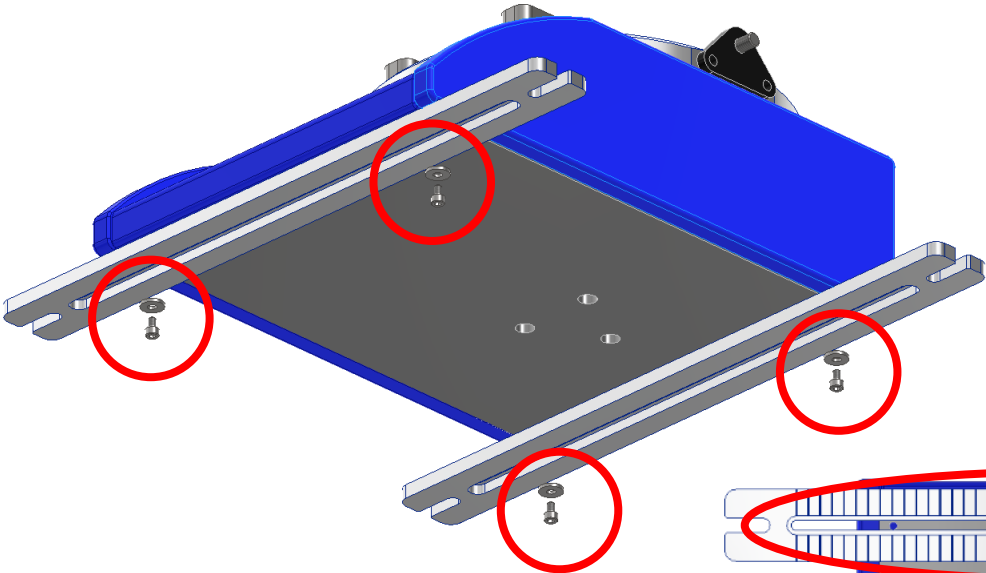

Positioning marks

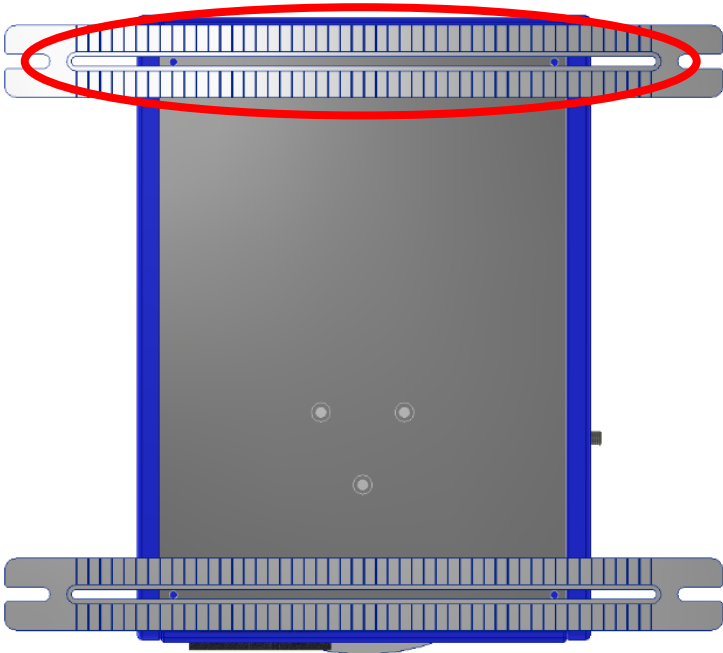

STEPS

1 / 2 / 3 / 4

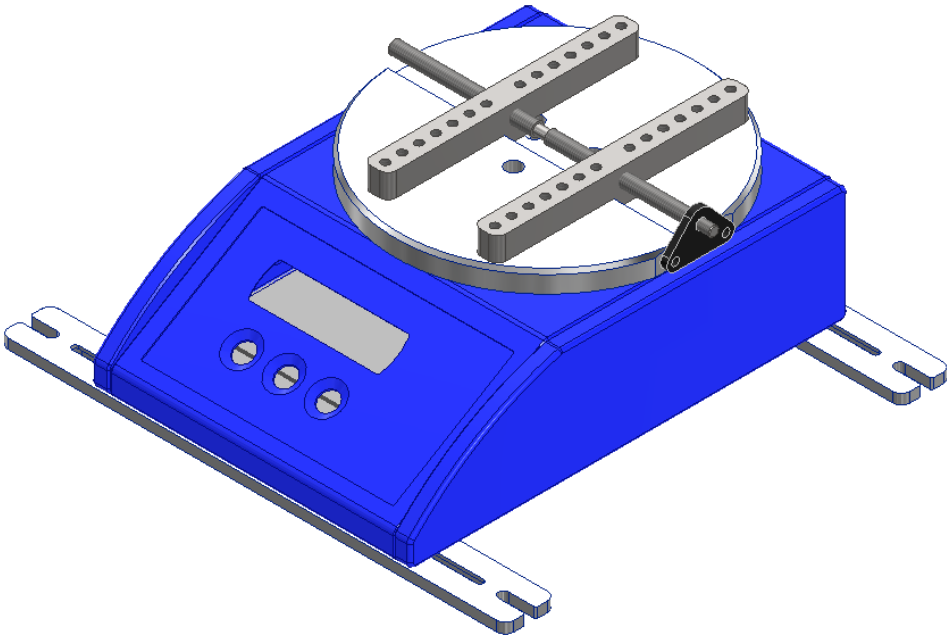

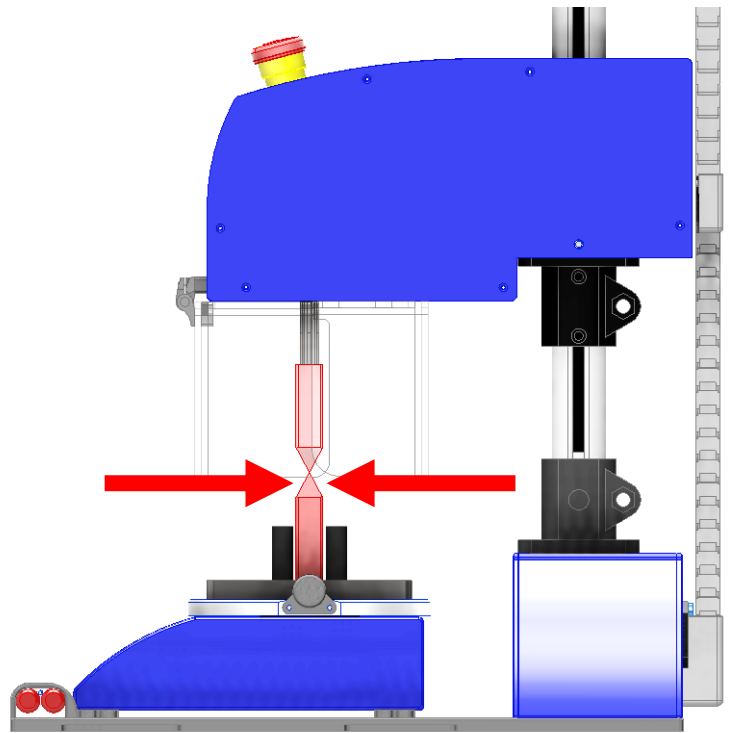
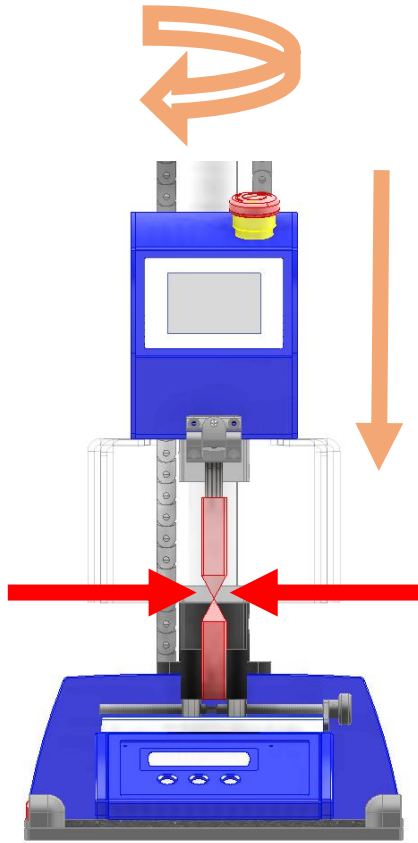

STEPS

5 / 6 / 7

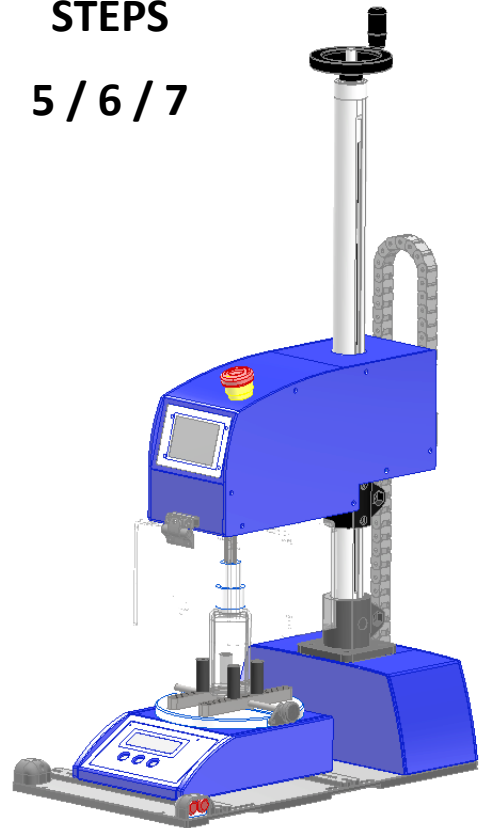
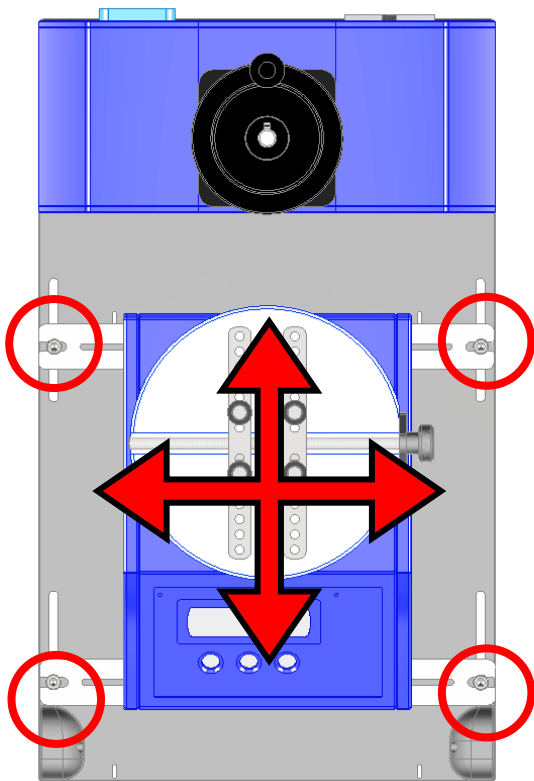

D. Mounting the clamp or jaw

To meet the wide variety of needs of REPEATORK users, it is possible to adapt the end of the rotating shaft. ACRN offers a whole range of clamps and jaws to suit most applications (large-scale production, low torque, quick changeovers, etc.).

To attach the clamp or jaw, slide the end onto the splined shaft and tighten the pressure screws firmly.

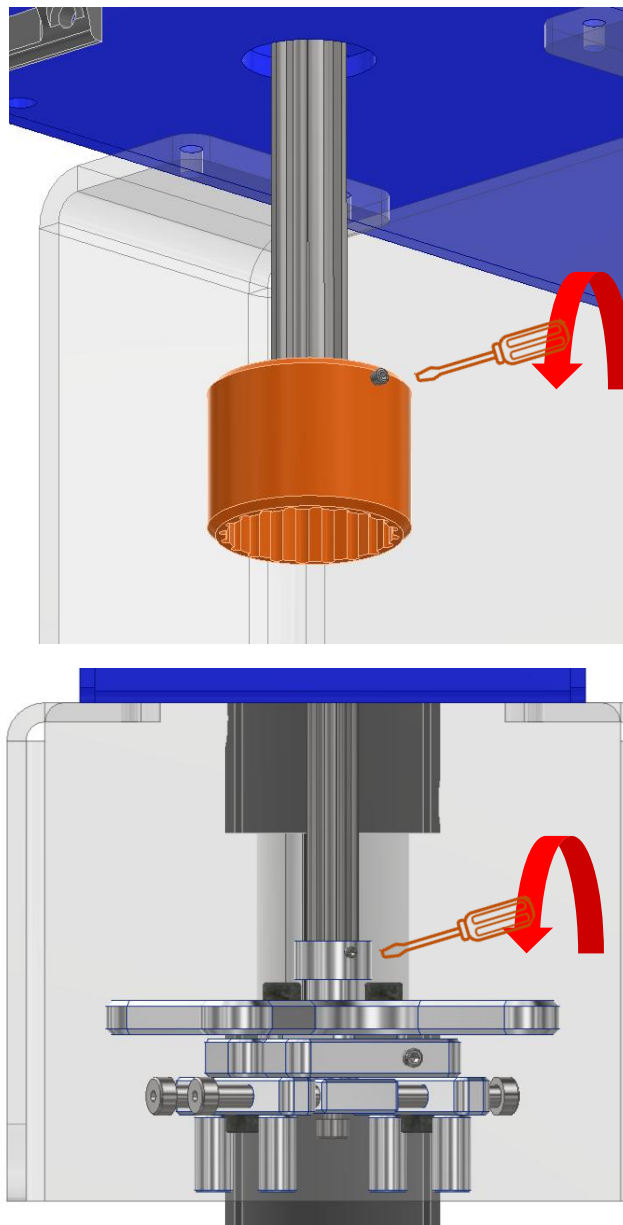

E. Disassembly of the device

The device must be disassembled with care to ensure operator safety.

Power off and disconnection

- Turn off the device using the switch located on the rear button of the device.
- Disconnect all power cables, including the device cable and the torque meter cable.
- Ensure that no cables remain under tension or are likely to be damaged during movement.

Removing the sample

- Remove the sample or any accessories attached to the measurement area.
- Check that the test area is free of any obstacles before continuing.

Moving around the operating site

- Handle the device with care. Wear gloves and safety shoes.
- Due to the total weight of the device and its torque meter (< 25 kg), two people are required to lift the device.
- When moving the device on the ground, use a stable trolley that is suitable for the load.
- Avoid any impact, excessive vibration, or stress on the mechanical components.

Temporary storage

- Place the device on a flat, stable surface.
- Protect sensitive components from dust, moisture, and impact (covers, connectors, measurement area).

F. Use of the device

a. General information

The device allows you to tighten and loosen screws at a predefined speed. For both directions of rotation, several stop conditions are possible (stop on angle, on torque, etc.).

The parameter setting interfaces allow you to configure the tightening and loosening movements **INDEPENDENTLY** according to your criteria, enabling you to create complex screwdriving and unscrewing sequences.

Examples of possible operations:

- Obtaining maximum unscrewing torque
- Achieving maximum unscrewing torque then re-tightening to a defined torque
- Determining the torsional torque of a part according to a predefined angle
- Performing precise unscrewing and re-screwing at an angle
- ...

Normal operation of the device

To perform a movement, it is necessary to:

- 1-Lower the safety visor (safety feature can be disabled, see settings section)
- 2-Enter the movement parameters (either screw-in or unscrew parameters)
- 3-Select the direction of the movement to be performed
- 4-Start the movement

These steps are detailed below.

b. Interfaces and movement settings

1. Main screen

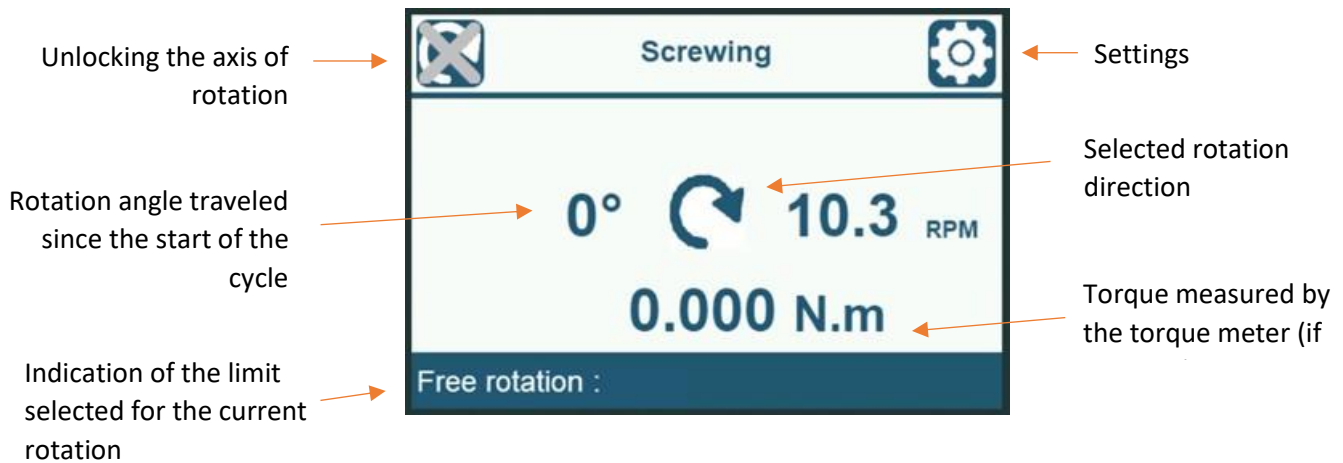

2. Movement settings

The button  gives access to the first page of settings:

Page 1 - Screwdriving movement settings 1/2

Page 2 - Screwdriving movement settings 2/2

Page 3 - Unscrewing movement settings 1/2

Page 4 - Unscrewing movement settings 2/2

Page 5 - Safety settings

Page 6 - Language settings

Parameter pages 1 and 3 (identical pages for tightening and loosening)

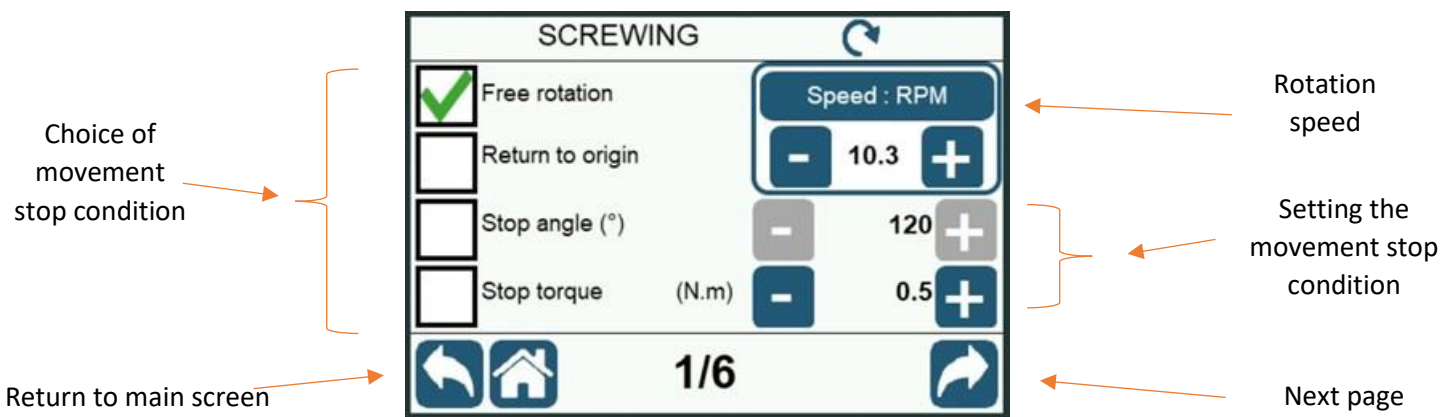

Details of movement stop conditions:

- **Free rotation:** rotation in the direction at the selected speed as long as the control buttons are held down by the operator.
- **Return to origin rotation:** Rotation until the measured angle reaches the final angle measured during the previous rotation. This movement only works if it occurs after a movement in the opposite direction.
Example of use: you want to know the maximum torque required to unscrew a cap and return the cap to its initial position.
This option allows you to return to the initial angle even if the unscrewing angle of the cap changes with each sample.
- **"Return to origin" rotation:** Rotation that starts from the last angle measured during the previous rotation and decreases until it reaches 0. Once 0 is reached, the rotation continues at its approach speed.
Example of use: you want to know the maximum unscrewing torque of a cap and return the cap to its initial position.
This option allows you to return to the initial angle even if the unscrewing angle of the cap changes with each sample.
- **Rotation with angle stop:** rotation in the direction at the selected speed as long as the angle measured since the start of rotation is less than the selected value.
- **Rotation with torque stop:** rotation in the direction at the selected speed as long as the torque measured on the coupling is less than the selected torque (this feature is only possible when using an ACRN torque meter).



If no torque meter is connected to the REPEATOR, the torque options will be disabled.

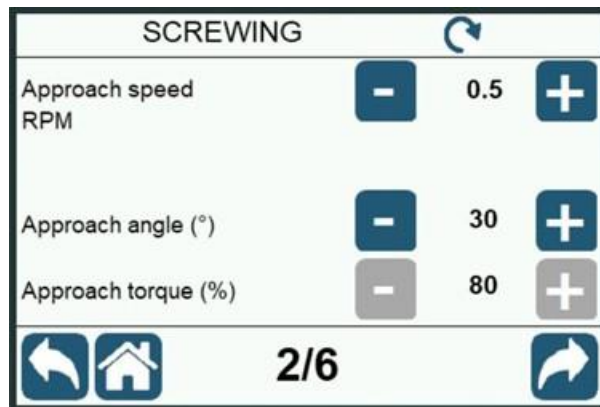

Details of additional movement settings:

Approach speed and angle: In order to improve angle stopping accuracy while maintaining a high rotation speed, it is possible to set the angle at which it is preferable to slow down the rotation.

For example, for a desired movement of 90° at 5 rpm, by setting the approach angle to 5° and the approach speed to 1 rpm, the device will perform the following sequence:

- 1- Rotation of 85° at 5 rpm
- 2- Rotations of 5° at 1 rpm

Approach speed and torque: In order to improve torque stopping accuracy and avoid sensor overload, it is possible to set the angle at which it is preferable to slow down rotation. The slowdown start value is a percentage of the target torque limit (set in the previous screen).

For example, for a desired rotational movement up to a torque limit of 5 N.m at 5 rpm and an approach torque of 90% and an approach speed of 1 rpm, the device will perform the following sequence:

- 1- Rotation at 5 rpm until the device measures 4.5 N.m (= 90% of 5 N.m)
- 2- Rotation at 1 rpm until the device reaches 5 N.m

i Following the slowdown due to the approach of the target torque, if the measured torque falls below the approach torque value, the device will not resume its initial speed but will remain at approach speed

i If no torque meter is connected to the REPEATOR, the torque options will be disabled

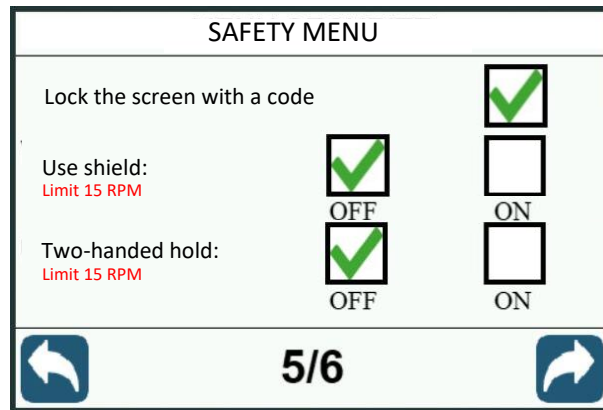

Use a security code: allows you to lock access to settings from the main screen. The code is fixed. **This code is 76**

Use of visor: Default setting is **ON**. It is possible to disable the use of the visor by setting it to **OFF**.
The unlock code is 76



CAUTION: this mode involves disabling a safety feature. It requires the user to be extremely vigilant and not to approach the machine when it is rotating. The speed is then limited to 15 rpm. ACRN recommends leaving the visor active to avoid any risk to the user of the device.

Two-hand control: Default setting is **ON**. Two-hand control of the drive control can be disabled by setting it to **OFF**.
The unlock code is 76.



CAUTION: this mode involves disabling a safety feature. It requires the user to exercise extreme caution and not to approach the machine while it is rotating. The speed is then limited to 15 rpm. ACRN recommends leaving the two-hand control active in order to avoid any risk to the user of the device.

Operating mode:

- 1- Select the direction by pressing a direction button
- 2- Start the movement by pressing the second start button near the direction button once
- 3- If necessary, stop by pressing any button



This page allows you to select the language in which you want to use the device

3. Select the direction of the movement to be performed and start the movement

Once the tightening and loosening movements have been set, you must choose the direction of rotation before starting the movement. To do this, use the two-hand control:

Step 1 - Select the direction of rotation by pressing buttons **1 OR 2** (Button 1 = unscrewing direction and Button 2 = screwing direction). Depending on your choice, the rotation direction arrow will update on the main screen.

Step 2 - Start the movement by pressing buttons **3 AND 4 SIMULTANEOUSLY**

Movement stop condition

- Depending on the movement settings (torque or angle).
- As soon as the operator releases either button 3 or 4.
- As soon as the visor is raised (if the visor requirement has been activated (by default)).
- As soon as the emergency stop is activated.

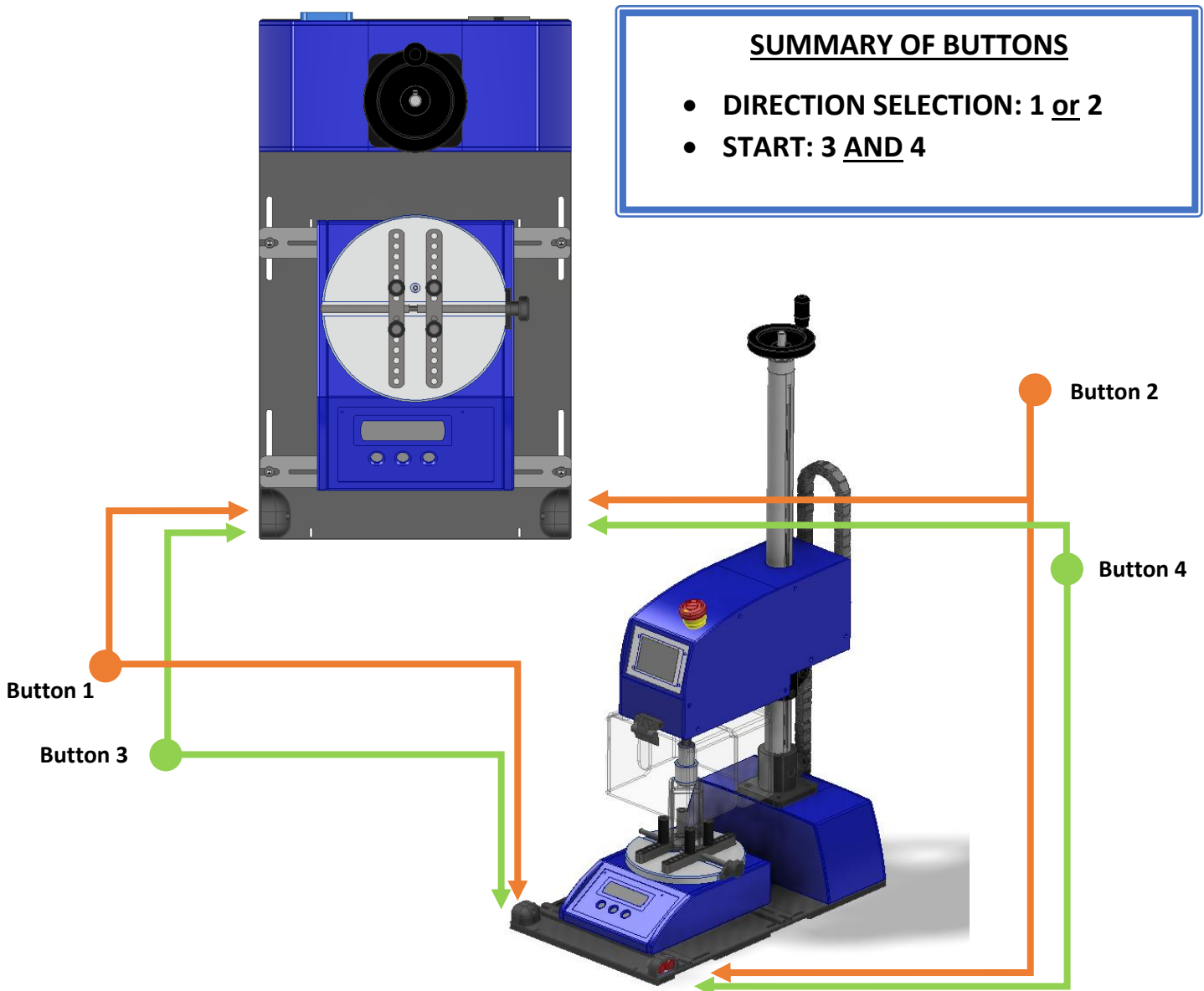

a. Manual rotation lock

When locking the HELITORK clamp, the motor shaft may rotate with the clamp.

To prevent this, which can cause alignment problems, the button locks the motor when pressed.





rotation

b. Screen lock

The REPEATORK can be locked to ensure that the configuration settings are as required.

The lock prevents access to the settings menu.

However, it is still possible to press the buttons.

To unlock the lock, press  and enter the code 76. The icon  appears.

The screen will automatically lock after 30 seconds of inactivity. You can manually relock the device by pressing 

It is possible to enable or disable the lock in the device settings

c. Torque meter configuration

To enable the device to work with your "NBA" or "NCA" torque meter, or Skilltork, follow this procedure:

1-Turn on the device.

2-Press the 3 buttons simultaneously until the "General Setup" menu appears.

3-Select the "RS232 Config." menu

4-Change the baud rate to "9600 bd."

5-Select "IMP" for the left button function.

6-In the case of an "NCA": disable the SP712 option: "SP712 OFF."

7-Press FIN

8- Select the "Ticket Conf." menu

9-Disable all options

10-Press END

11-Restart the device and the torque meter

G. Using the digital ruler (OPTION)

The digital ruler allows you to accurately determine the height position of the column. This improves the repeatability of unscrewing by ensuring identical positioning and allows you to adjust the height of the column more quickly when changing samples.



a. Operation

The digital ruler displays the height during movement. It is not necessary to turn the ruler off or on before and after use; the ruler goes into standby mode and reactivates automatically when it detects column movement. However, it is possible to turn it off and on by pressing ON/OFF, without losing the current position

b. Zero adjustment

If you press 0 by mistake, or if you change batches or for any other reason, you may need to reset the initial position in order to restore the initial settings (absolute zero).

ACRN provides an initial position adjustment wedge that allows you to return to the factory settings with certainty. Setting this 0 to this predefined height is ACRN's choice, but it is possible to set your own 0 for operational reasons or reasons specific to the control process. To do this, the person in charge of control must set up a repeatable means of fixing the initial position (wedge, ruler placed on the chassis, etc.) in order to return to the absolute zero defined by the person responsible for this operation.

To make the adjustment with ACRN equipment:

- 1- Place the wedge on the column

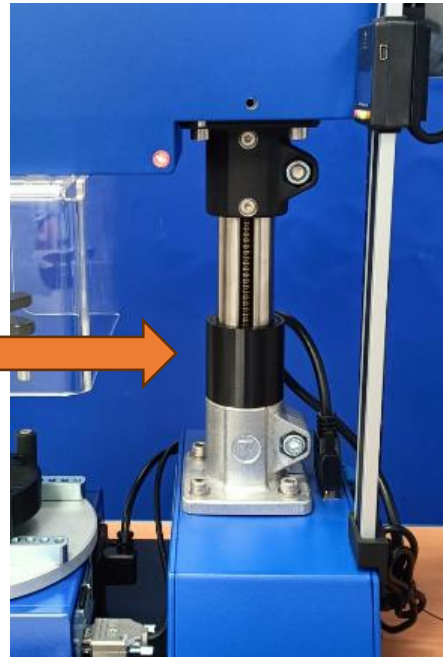
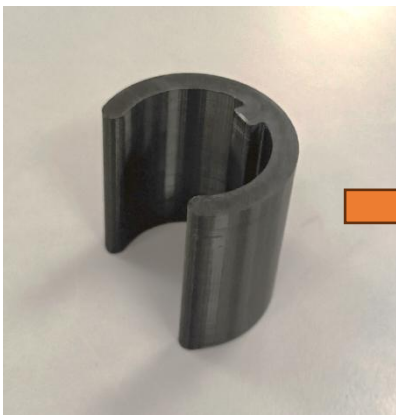

- 2- Lower the column to rest on the wedge

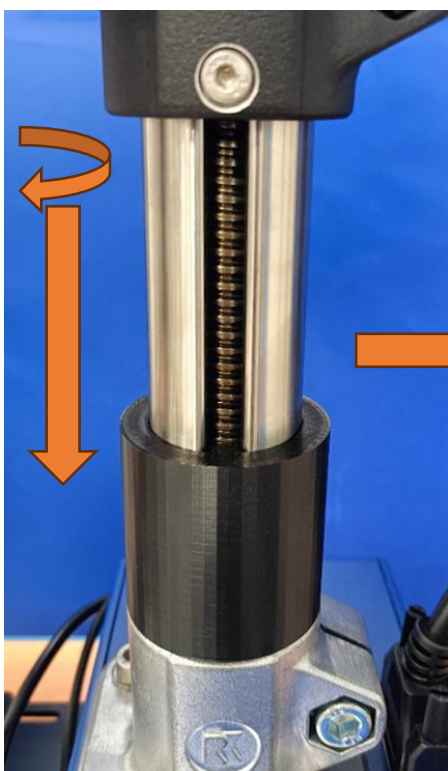

3- Press the 0 on the ruler

The "absolute" zero is now set

It is then possible to set a "relative" zero, the position of which will be controlled.

Example: setting a relative zero 35 cm above the absolute zero. This can constitute a "factory zero."

This method guarantees repeatable positioning.



H. Use of the child-resistant closure (CRC) system (OPTION)

CRC (Child-Resistant Closure) caps require a minimum amount of force to unscrew them. The Repeatork's CRC option allows this force to be applied without handling heavy weights, while maintaining the ergonomic beating system of the unscrewing head for installing and removing samples.

This option requires modification of the machine (carried out in the workshop) and the addition of a force sensor and a measuring console.

a. Installation diagram

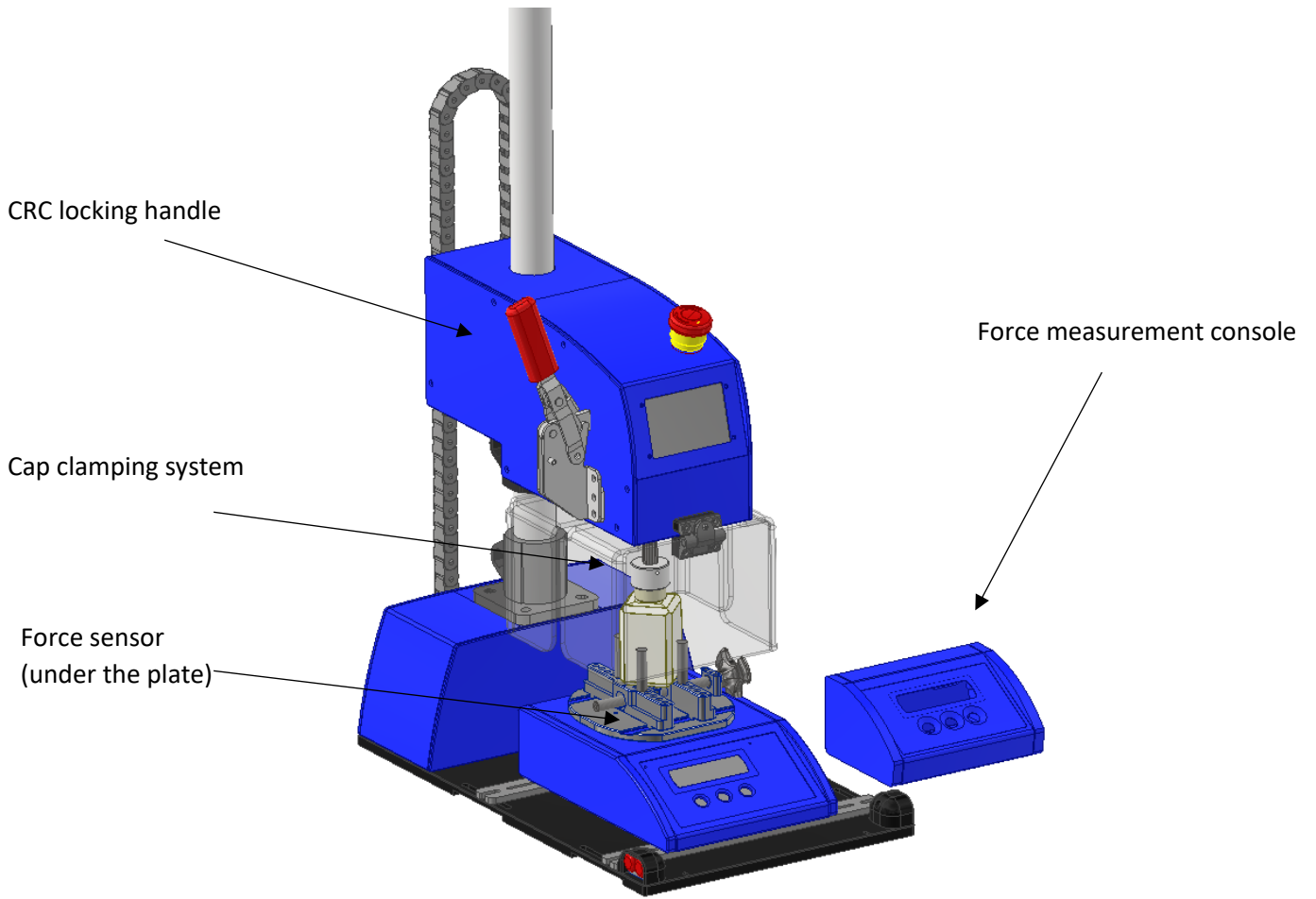

b. Description and operation

To perform CRC tests:

1- Check that the CRC system is unlocked

- The handle must be in the down position
- The cap clamping system must not be in contact with the cap

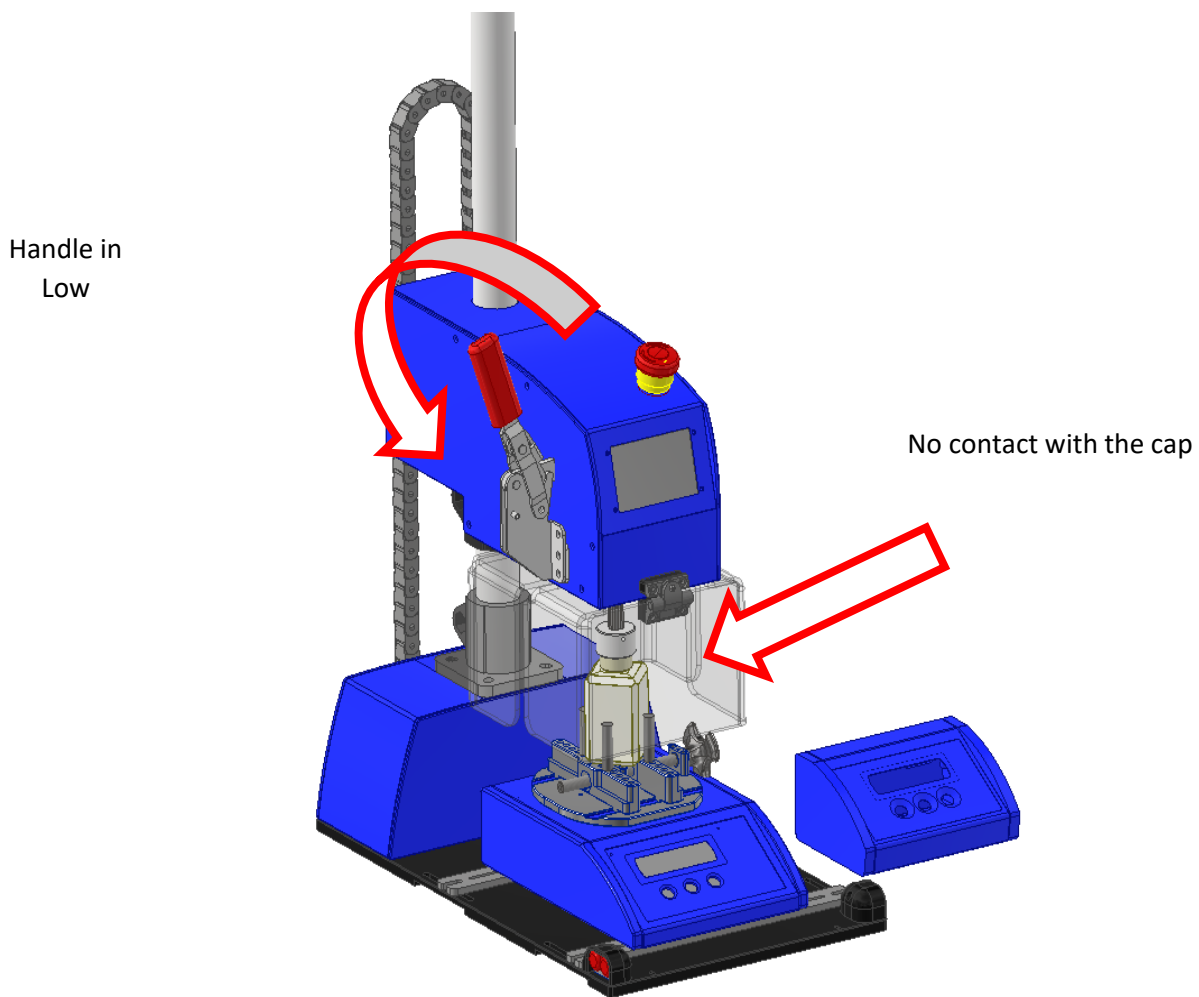

2- Calibrate the force sensor

Calibrate the measuring console so that the force displayed is 0

3- Install the sample in the lower and upper parts

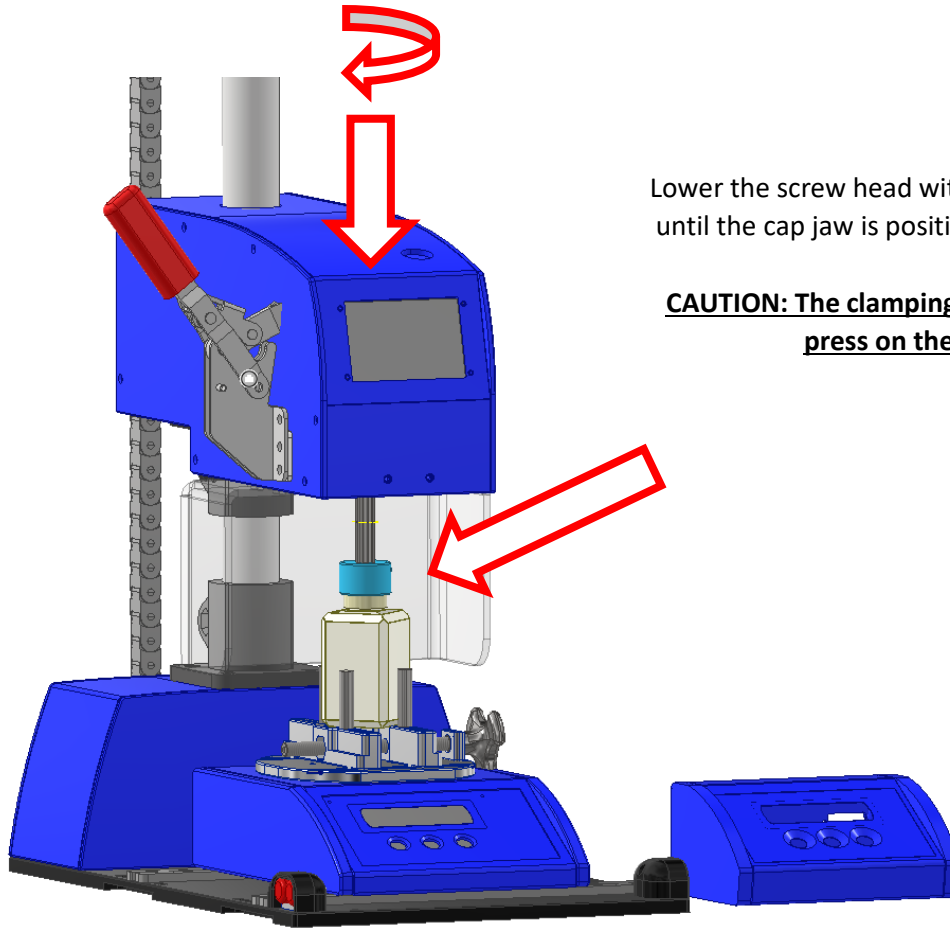

Lower the screw head with the handwheel until the cap jaw is positioned on the cap.

CAUTION: The clamping head must not press on the cap

4- Lock the CRC system.

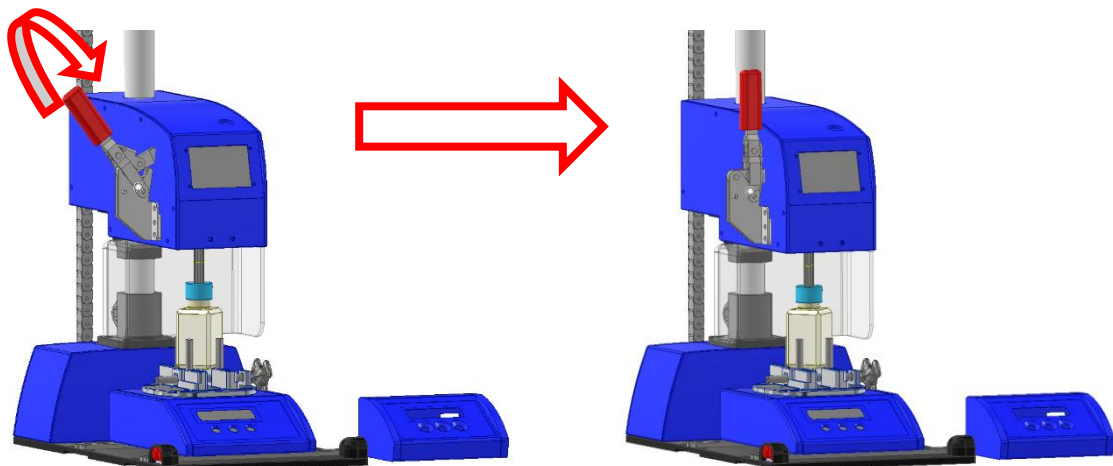

5- Lower the column to the desired force, displayed on the console.

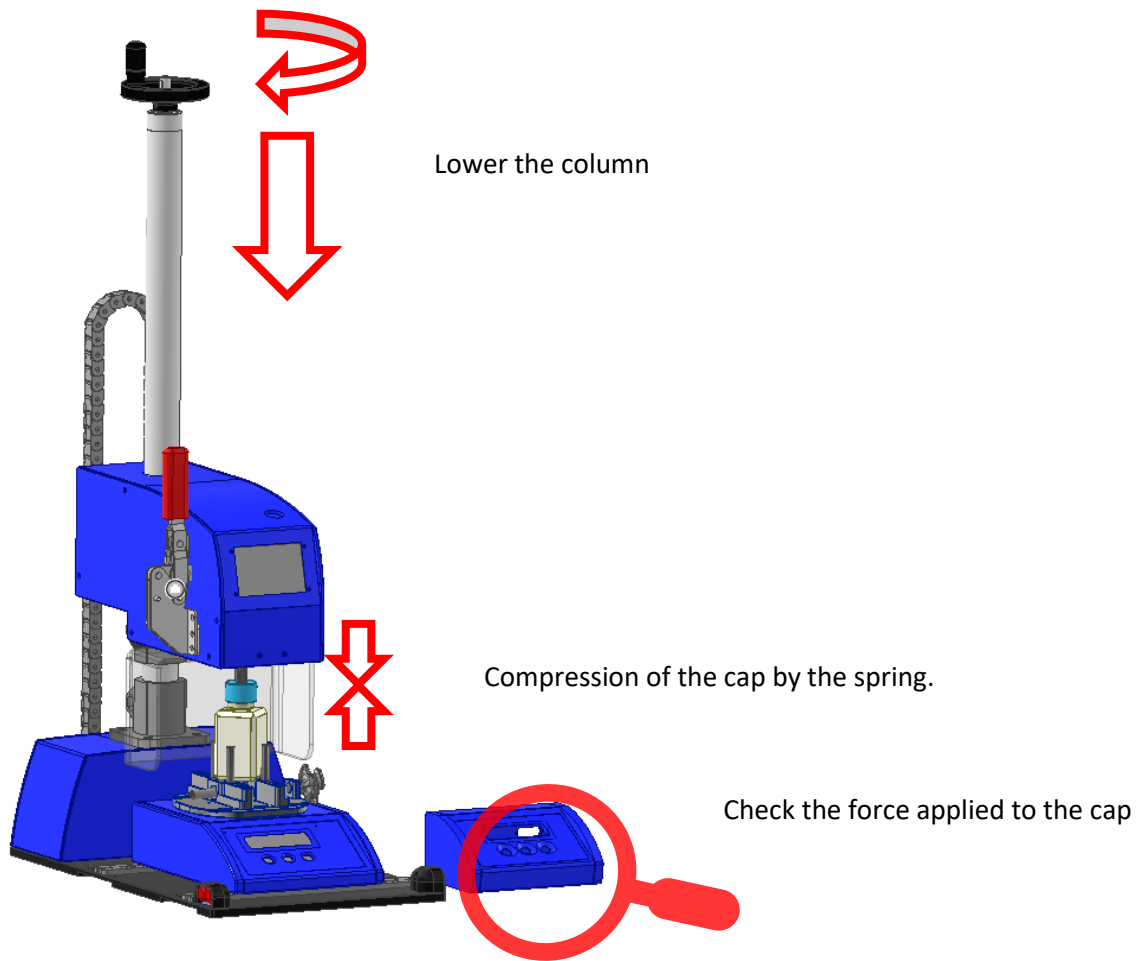

6- Unscrew using the Repeatork by selecting the unscrew direction and then pressing the two buttons simultaneously (two-hand control)

7- Unlock the CRC system and change the sample

Once adjusted, it is not necessary to readjust the pressure between two identical samples.

CAUTION: As soon as the height adjustment wheel is turned up or down, it is necessary to recheck the force applied to the cap.

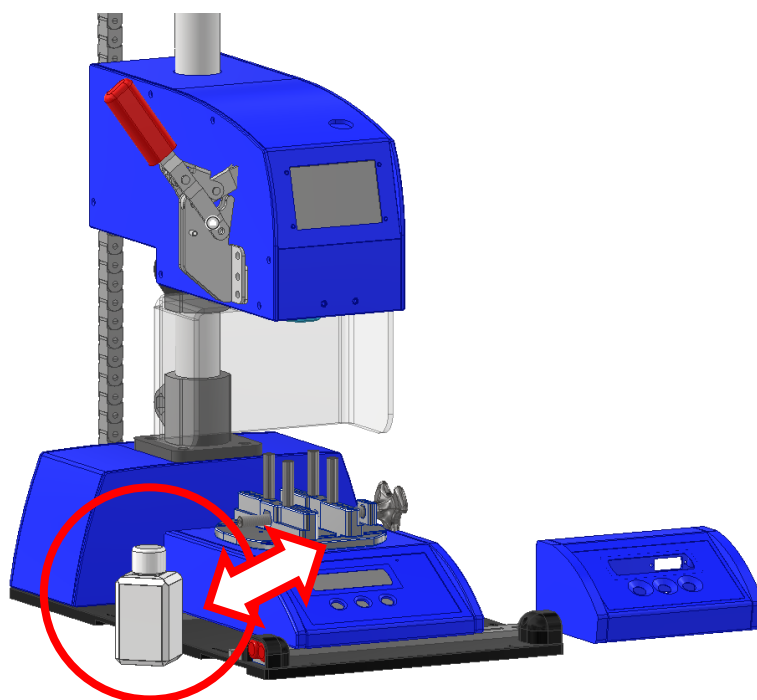

V. Maintenance - Maintenance operations

A. Maintenance

OPERATION	FREQUENCY	OBSERVATION
Check the general condition of the machine	Each time the machine is used	The device must be in good apparent condition before use.
Checking the sensor calibration	Once a year	Contact ACRN to have the calibration performed
Checking the calibration of the rotation speed	Once a year	Contact ACRN to perform calibration
Safety device tests: Visor, emergency stop button, two-hand control.	Once a week	Contact ACRN immediately in the event of a defective safety device.

B. Cleaning

The device is suitable for use in various industrial environments.

Regular cleaning with warm water and a mild detergent (pH between 6 and 8) is sufficient to ensure cleanliness and longevity.

The use of strongly acidic, alkaline, abrasive, or powerful solvent products is **prohibited** as they may damage the surface finish.

VI. [Transport outside the device's operating site](#)

For all transport, it is strongly recommended that the device be placed in a suitable cardboard box equipped with foam or cushioning material. When shipping, make sure to close the box securely and attach it firmly to a shipping pallet.

Note: After transport, refer to the safe installation instructions before putting the dynamometer back into service.

VII. [FAQ – Frequently asked questions](#)

- **The device does not start or the torque meter connected to the auxiliary power supply does not turn on**
 - 1-Check that you have connected the device correctly and turned on the switch at the back of the device.
 - 2-Check that the emergency stop button is released
 - 3- Check the condition of the fuse in the main socket of the device located in the switch at the rear of the device (a spare fuse is supplied with the device).If the device still does not start after checking these points, please contact your dealer.
- **Pressing the side buttons does not start the motor**
 - 1-Check that you have lowered the safety visor. If this is not the case, the icon will appear  on the screen
 - 2-For safety reasons, after pressing the RUN button, the two-hand control buttons must be pressed simultaneously and held down while the device is rotating.
- **The motor block attached to the mast has play and moves when raising/lowering or rotating.**

Check that the internal screw on the side of the blue housing is properly tightened. If this knob is not tight enough, the housing will have too much freedom and centering with the torque meter will not be guaranteed. If the knob is too tight, it will become difficult to raise and lower the housing attached to the mast using the handwheel.
- **The torque meter value does not appear on the main screen**
 - 1-Check that the torque meter is properly connected to the device.
 - 2-Check that the torque meter is correctly configured for the device.

VIII. Declaration of conformity

EC DECLARATION OF CONFORMITY

ACRN, located at Parc d'Activités du Moulin d'Ecalles, 76750 Buchy, France

Declares that the following equipment:



complies with the regulatory provisions defined in Annex I of European Directive 2006/42/EC concerning the technical rules and conformity certification procedures applicable to it,

as well as European Directive 2014/30/EU on the harmonization of the laws of Member States relating to electronic compatibility.

This equipment is validated according to the following standard:

- **EN 61326-1: 2013** Electrical equipment for measurement, control and laboratory use, EMC requirements. General requirements.

Technical notice editor: Etienne DUPUY

Date: 27/2025

Signatory name: Etienne DUPUY

Position: Managing Director **Apprc**



IX. Appendices

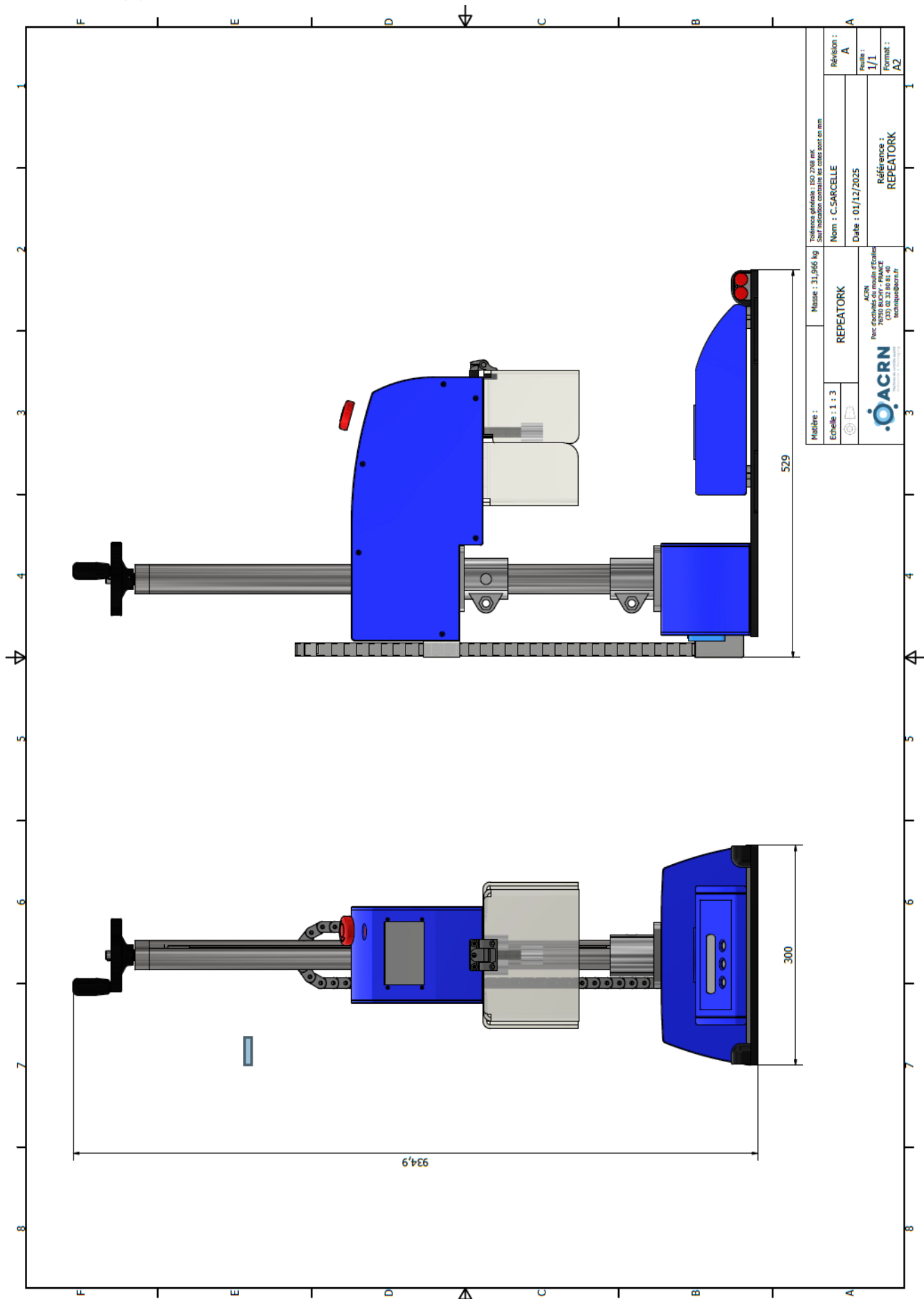

Matière :		Tolérance générale : 150 ± 0,2768 mm. Sauf indication contraire les cotes sont en mm	
Echelle : 1 : 3		Nom : C.SARCELLE	
REPEATORK		Date : 01/12/2025	
ACRN Pour d'obtenir toute d'écrite 70350 BACLY - FRANCE (03) 02 32 80 81 40 www.acrn.fr		Révision : A	
Référence : REPEATORK		Échelle : 1/1	
		Format : A2	



ACRN

Machines de contrôle qualité
Industrie & Packaging

CATALOGUE PRODUITS



MESURE
DE COUPLE



FORCE ET
DYNAMOMÉTRIE



TESTS DE FUITE
ET ÉTANCHÉITÉ

CONTRÔLE DE SERRAGE

DYNAMOMÉTRIE ÉLECTRONIQUE

CONTRÔLE QUALITÉ CALIBRATION

ÉTANCHÉITÉ

CAPTEURS COUPLEMÈTRE

SPÉCIALISTE DU CONTRÔLE PACKAGING